

MODEL NUMBER	IEEE100-18-405T		
HORSEPOWER	100		
RPM / POLES	1800 / 4		
VOLTAGE / PHASE	460 / 3		
FRAME	405T		
ENCLOSURE / DEGREE OF PROTECTION	TEFC / IP55		
FREQUENCY	60 HZ		
FULL LOAD SPEED	1780 RPM		
SERVICE FACTOR	1.15		
INSULATION CLASS	F Class N Varnish		
FULL LOAD AMPS	114.1 A		
LOCKED ROTOR CURRENT (% Full Load)	650 %		
NEMA CODE LETTER	G		
EFFICIENCY / POWER FACTOR	<u>LOAD</u>	<u>EFF.</u>	<u>P.F.</u>
	100 %	95.4 %	86.5 %
	75 %	95.4 %	84.5 %
	50 %	94.1 %	78.4 %
DUTY CYCLE	S1 / Continuous		
TORQUE	<u>FULL LOAD</u>	<u>LRT</u>	<u>BDT</u>
	296.8 lb.ft	140 %	220 %
NEMA DESIGN	B		
MOMENT OF INERTIA	<u>LOAD (Max.)</u>	<u>MOTOR</u>	
	1337.213 lb.ft ²	35.910 lb.ft ²	
SOUND PRESSURE LEVEL (No Load 1 M From Motor)	82 dB(A)		
MAX. SHAFT VIBRATION	0.08 In/Sec – Peak Velocity		
NUMBER OF STARTS (Hot / Cold)	2 Hot / 3 Cold		
MAX. AMBIENT TEMPERATURE	40° C		
MAX. ELEVATION	3300 Ft. Above Sea Level		
TEMPERATURE RISE (At Full Load)	80° C		
DRIVE-END BEARING	NU316		
OPPOSITE DRIVE-END BEARING	6313C3		
BEARING SEAL TYPE	ProTech™ IP66 Labyrinth On DE and ODE		
GREASE TYPE	Mobil Polyrex EM		
MOUNTING	F1 (F2 Suitable), W6, W8, B3, V5, V6		
ROTATION	Bi-Directional		
APPROXIMATE WEIGHT	1110 lbs		
AREA CLASSIFICATION	Class I, Division 2, Groups A, B, C, D, T3A		
PAINT	Epoxy		
INVERTER RATING	10:1 CT / 1000:1 VT		
INSULATION TYPE	Hyundai Inverter Shield, Meets NEMA MG1 Part 31		
SPECIFICATION - In Accordance With	IEEE-841, Version 2009, NEMA, CSA		



CC 038A



본 도면은 현대중공업(주) 재산이며 복제할 수 없습니다 (취급유의)

THIS DRAWING IS PROPRIETARY TO HEECO. NO PART OF THIS DRAWING MAYBE REPRODUCED WITHOUT THE PERMISSION OF HHI.

		IEEE841 TEFC THREE PHASE INDUCTION MOTOR		TYPE	PLP Cast iron frame
FRAME SIZE	OUTPUT(HP)	POLES	Hz	TIME RATING	
405T			60	CONT	

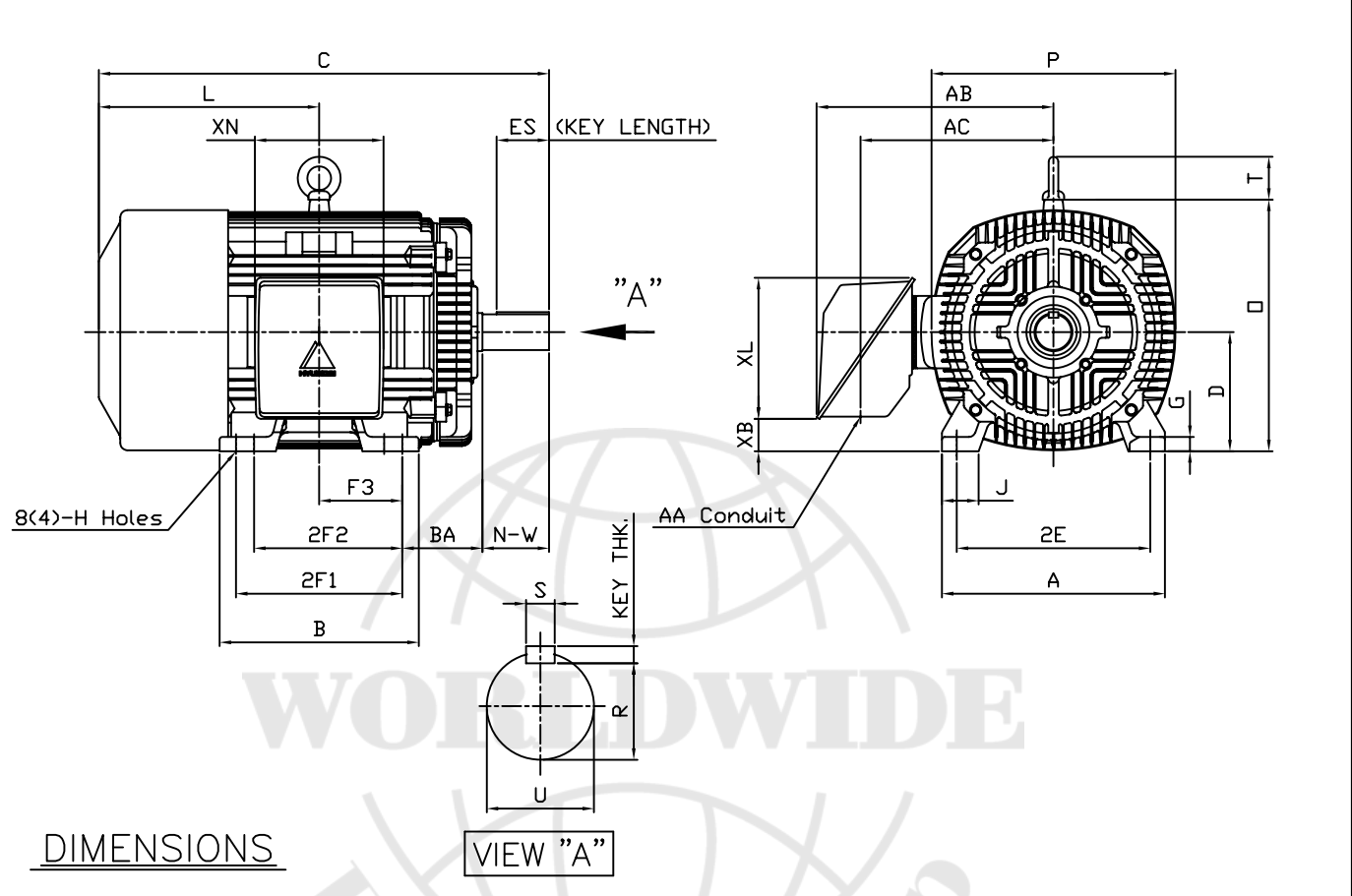

DIMENSIONS

VIEW "A"

M O U N T I N G									C O N D U I T B O X					APPROX. WGT.(LB)	
A	B	2E	2F1	2F2	F3	G	J	H	AA	AB	AC	XB	XL	XN	
18.43	16.46	16.00	13.75	(12.25)	6.870	1.18	3.03	0.81	3.00	20.28	14.85	2.83	11.65	10.63	1220

O V E R A L L								S H A F T			KEY	BEARING		
BA	C	D	L	O	P	T	U	N-W	KEYWAY			THK.	DRIVE END	OPP. DRIVE END
									R	ES	S			
6.62	41.01	10.00	20.57	20.79	20.16	3.55	2.875	7.25	2.450	5.65	0.750	0.750	NU316	6313C3

NOTE

1. Dimension "D" tolerance : +0.00inch - 0.03inch (143T-365T) ; +0.000inch - 0.06inch (404T-449T)
2. Dimension "U" tolerance : +0.000inch - 0.005inch (143T-215T), +0.000inch - 0.001inch (254T-449T)
3. Dimension "R" tolerance : +0.000inch - 0.015inch

Q'TY	DESCRIPTION	MATERIAL	DIMENSION	WEIGHT	PART NO.	REMARK	NO.
APPD BY	K.J.KANG	UNIT	INCH	SUBJECT	405T	CAD PROJ ㄹ \ FILE ㄹ	
Q.P CHK	O.J.KIM	SCALE	N/S				
CHKD BY	N.D.LEE	PROJEC'N	3 각법(3rd Angle)	TITLE			
DSND BY	A.L.SHIN	DATE	2011.03.31				



REF. NO	A8116AA	Sheet No. of	
DWG NO	350A8116AA	Revision No.	0

Type	: PLP
Full Load Torque	: 296.8 lb.ft
Motor moment of Inertia (J)	: 35.910 lb.ft ²
Load moment of Inertia (J)	: 1337.213 lb.ft ²

75 kW	100 HP	60 Hz
4 P	Rated Speed : 1780 RPM	
Rated Voltage	460V	
Full Load Current	114.1A	

SPEED VS TORQUE & CURRENT CURVE

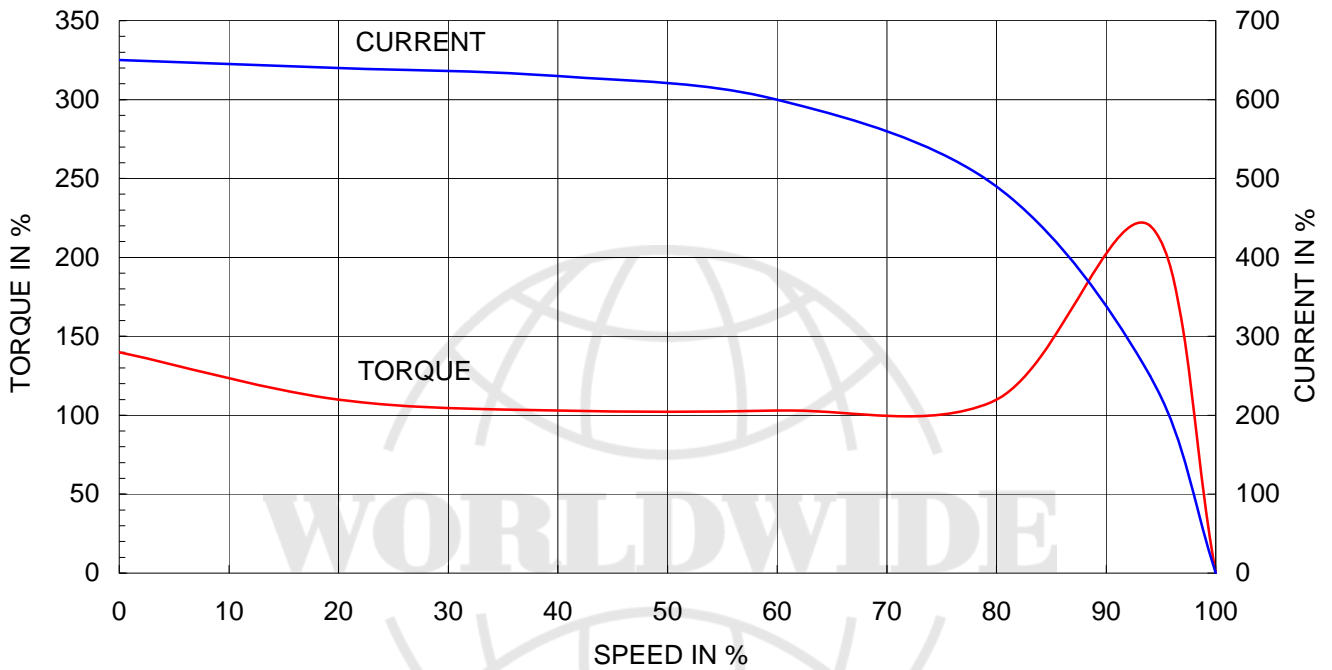

OUTPUT VS EFF., P.F & CURRENT CURVE

