



# WORLDWIDE ELECTRIC MOTOR DATA SHEET



## WSS13-18-56CRD

HP	1/3
RPM / POLES	1800 / 4
VOLTAGE / PHASE	230 / 460 V / 3
FRAME	56C
ENCLOSURE	TEFC
FREQUENCY	60 HZ
RATED SPEED	1725 RPM
FULL LOAD AMPS	1.4 / 0.7 A
DUTY CYCLE	CONTINUOUS
SERVICE FACTOR	1.15
INSULATION CLASS	F
RATED TORQUE	1.0 LB. FT.
LOCKED ROTOR TORQUE	288%
BREAKDOWN TORQUE	388%
LOCKED ROTOR AMPS (STARTING)	7.4 / 3.7 A
NO LOAD CURRENT	0.58 / 0.29 A
BASE TYPE	C-FACE - ROUND BODY
SHAFT	KEYED
DE BEARING	6205 DDU
ODE BEARING	6205 DDU
MOUNTING	F1
ROTATION	CW / CCW
OVERLOAD	---
START CAPACITOR	---
RUN CAPACITOR	---
WIRE TYPE	LOOSE WIRE
WIRE HOUSING	JUNCTION BOX
ROTOR INERTIA	0.07809 LB. FT. <sup>2</sup>
SHAFT MATERIAL	304 STAINLESS STEEL
CONNECTION DIAGRAM	230 / 460 V - 9 LEAD Y
APPROX. WEIGHT	28 LBS.
POWER FACTOR	0.71
FL EFFICIENCY	82.5%



REVISED - 08/30/12



WORLDWIDE ELECTRIC MOTOR DRAWING  
**WSS13-18-56CRD**

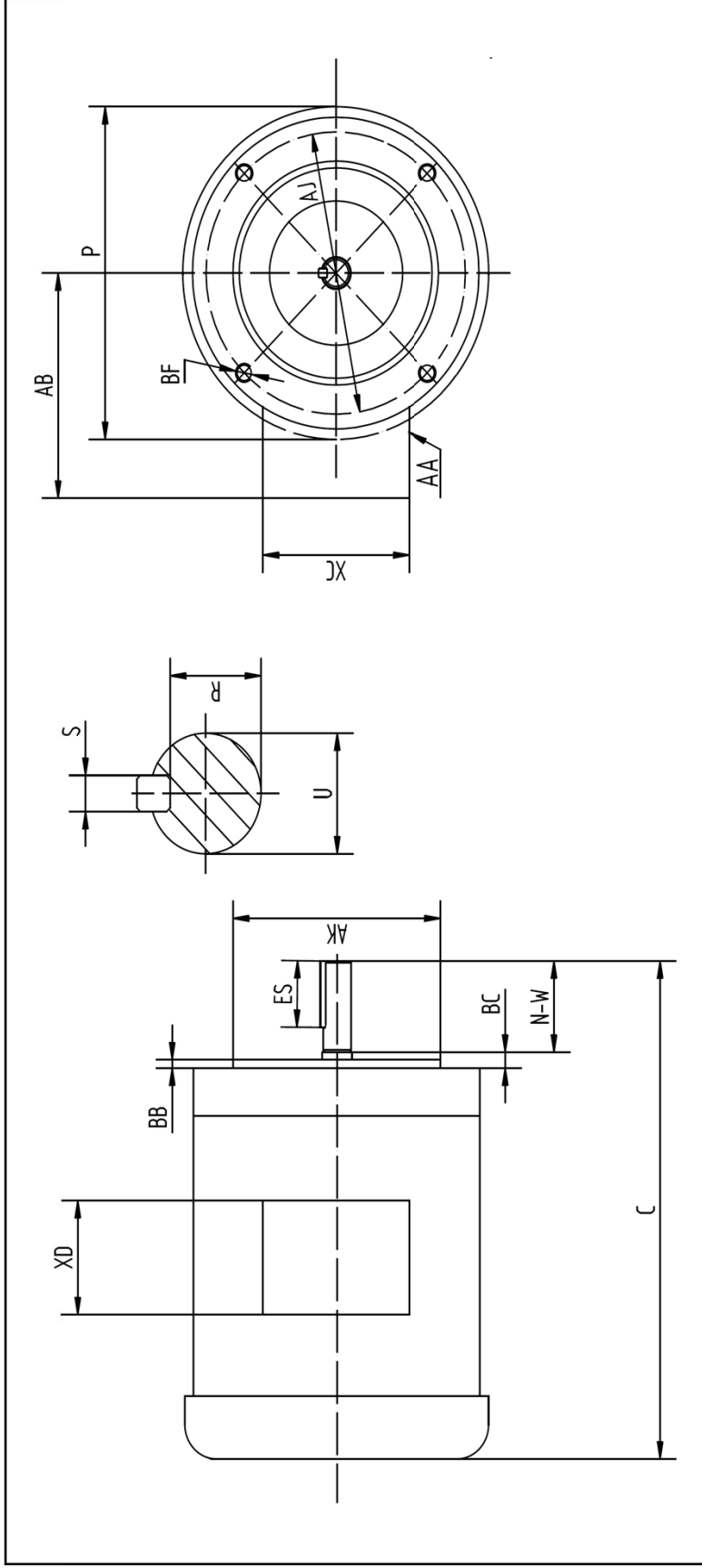

C	P	KEY			KEYSEAT		
		AA	AB	BC	ES	S	R
11.59	8.5	0.86	5.75	0.19	1.41	0.188	0.517

FLANGE		SHAFT		TERMINAL BOX			
AJ	AK	BB	BF	N-W	U	XC	XD
5.875	4.5	0.16	3/8-16	1.88	0.625	3.27	3.8

ALL DIMENSIONS IN INCHES