



WORLDWIDE ELECTRIC MOTOR DATA SHEET



WSSNV12-18-56CRD

HP	1/2
RPM / POLES	1800 / 4
VOLTAGE / PHASE	230 / 460 V / 3
FRAME	56C
ENCLOSURE	TENV
FREQUENCY	60 HZ
RATED SPEED	1725 RPM
FULL LOAD AMPS	1.5 / 0.75 A
DUTY CYCLE	CONTINUOUS
SERVICE FACTOR	1.15
INSULATION CLASS	F
RATED TORQUE	1.5 LB. FT.
LOCKED ROTOR TORQUE	250%
BREAKDOWN TORQUE	347%
LOCKED ROTOR AMPS (STARTING)	9.6 / 4.8 A
NO LOAD CURRENT	0.6 / 0.3 A
BASE TYPE	C-FACE - ROUND BODY
SHAFT	KEYED
DE BEARING	6205 DDU
ODE BEARING	6205 DDU
MOUNTING	F1
ROTATION	CW / CCW
OVERLOAD	---
START CAPACITOR	---
RUN CAPACITOR	---
WIRE TYPE	LOOSE WIRE
WIRE HOUSING	JUNCTION BOX
ROTOR INERTIA	0.09290 LB. FT. ²
SHAFT MATERIAL	304 STAINLESS STEEL
CONNECTION DIAGRAM	230 / 460 V - 9 LEAD Y
APPROX. WEIGHT	31 LBS.
POWER FACTOR	0.76
FL EFFICIENCY	82.5%



WORLDWIDE ELECTRIC MOTOR DRAWING
WSSNV12-18-56CRD

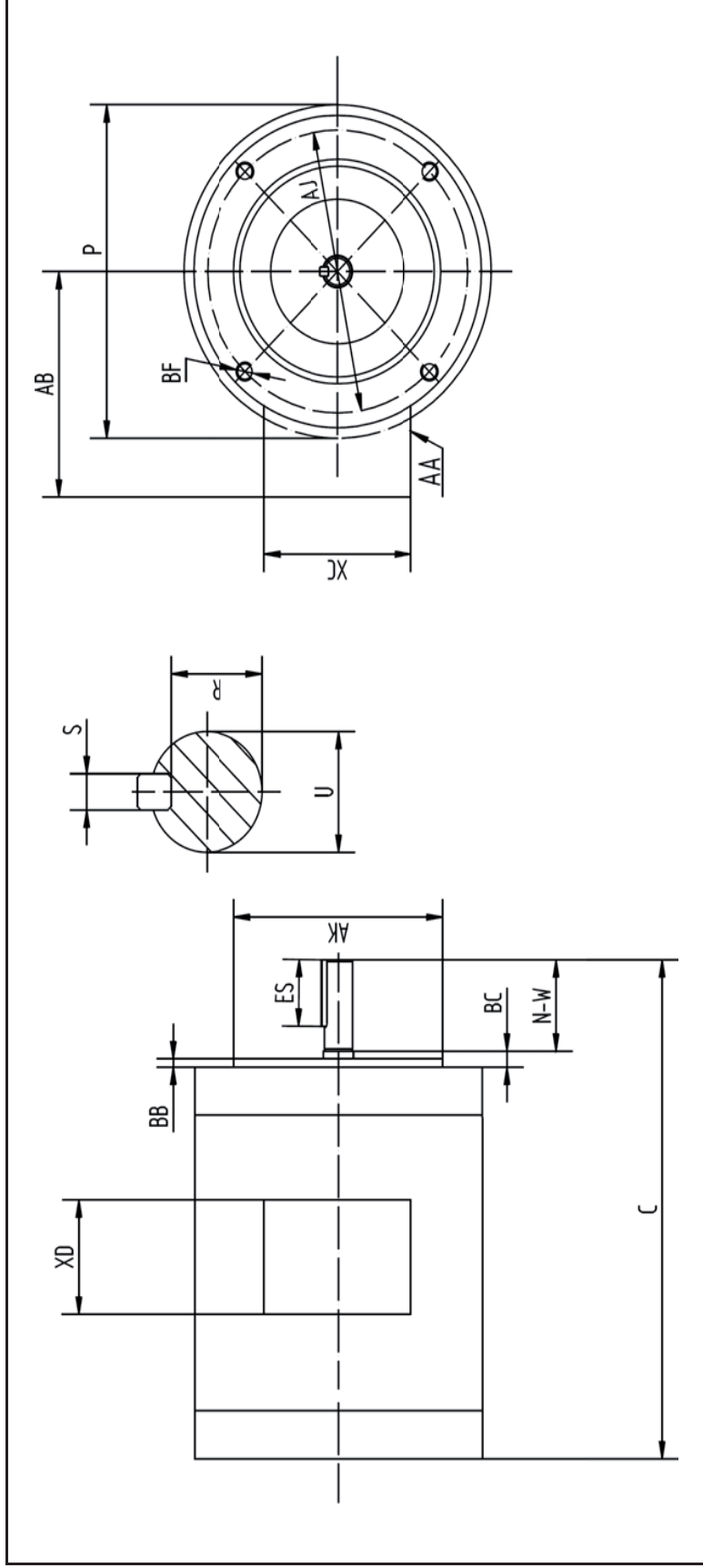

		KEY		KEYSEAT		
C	P	AA	AB	ES	S	R
9.8	6.5	0.86	5.75	1.41	0.188	0.517

		SHAFT		TERMINAL BOX			
AJ	AK	BB	BF	N-W	U	XC	XD
5.875	4.5	0.16	3/8-16	1.88	0.625	4.72	3.8

ALL DIMENSIONS IN INCHES